



Autotech Sport Tuning Corporation  
 29 Journey • Aliso Viejo, CA 92656-3333 USA  
 Tel +1 949 362 8700 • Fax +1 949 362 8720  
 info@wavetrac.net • www.wavetrac.net

## INSTALLATION NOTES

10.309.185WK  
 10.309.186WK  
 10.309.187WK  
 10.309.188WK

### VOLKSWAGEN GROUP 02E (DSG)



## READ BEFORE STARTING INSTALLATION!

### PARKING BRAKE TOOTHED RING DIFFERENCES:

The differentials in Volkswagen 02E series dual clutch transmissions (DSG) feature a toothed ring on the body that is engaged by a claw when shifted to "park," acting as the parking trans-brake does in automatic transmissions.

There have been two styles of this toothed ring used in the DSG over the years. The early (coarse) ones have 20 teeth, while the late (fine) ones have 25 teeth.

Before fitting the Wavetrac®, verify that it has the matching toothed ring as your original differential. Do not install anything (bearings, ring gear, etc.) on the Wavetrac® before checking this!

If the Wavetrac® does not match tooth for tooth with your stock unit, contact us to arrange an exchange, which can be done without cost to you as long as you haven't fitted the Wavetrac®.

**tel: +1 949 362 8700**  
**email: tech@wavetrac.net**

The drawings on the following pages illustrate what the differences are between Wavetrac models.

### RING GEAR BOLT TORQUE SETTINGS:

Wavetrac® differentials for DSG models come with ARP® ring gear bolts included.

As with most other VW applications, the oem diff and ring gear are riveted together, so drilling out the rivets is required for disassembly.

For installation of the ring gear on the Wavetrac®:  
 Tighten in an alternating pattern for stress free mounting of the ring gear.

**Torque bolts to 85 ftlbs (115Nm) using loctite 242**

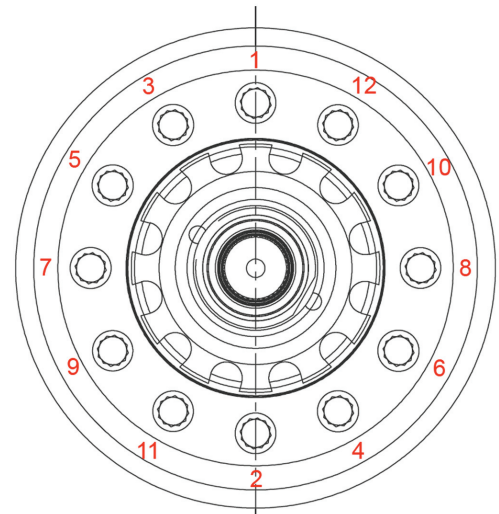

# DSG 2WD VARIANTS

10.309.187WK

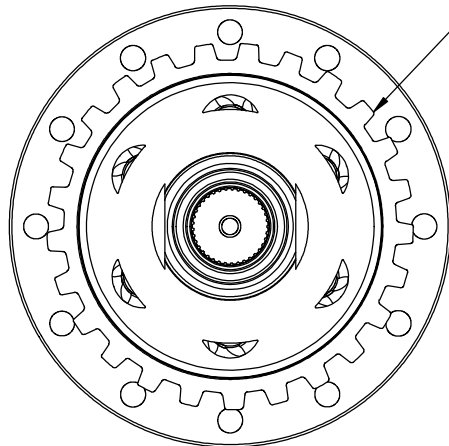
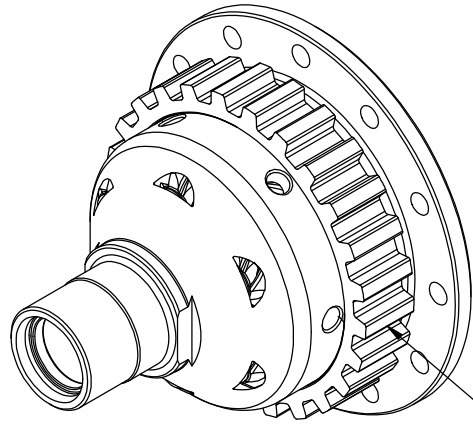

25 TEETH

10.309.185WK

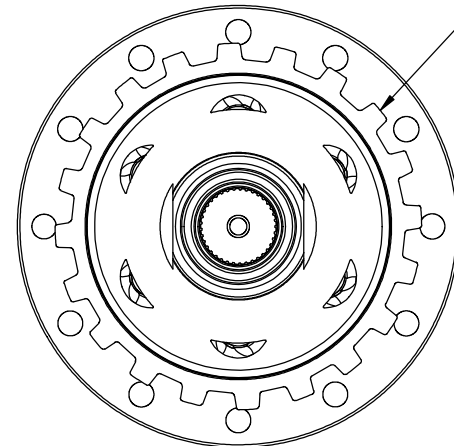
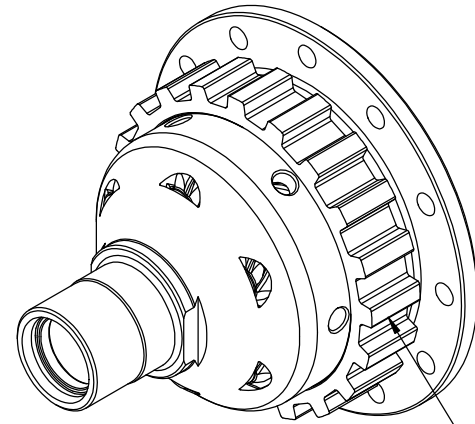

20 TEETH

<b>DEFAULT TOLERANCES</b> UNLESS OTHERWISE SPECIFIED X.X ±0.30 [.012] X.XX ±0.05 [.002] ANGLES ±2°				Autotech Sport Tuning Corporation 29 Journey Aliso Viejo, CA 92656-3333 USA +1-949-362-8700		
	ALL DIMENSIONS IN: MILLIMETERS [INCHES]	<b>A</b> RELEASED TO PRODUCTION REV DESCRIPTION DATE		12/17/12 DATE	DWG. PART NUMBER SIZE 248-01R-002 REL. A	DESCRIPTION DIFF VARIANTS
<b>UNDIMENSIONED FEATURES:</b> RADIUS: 0.4 - 1.0 [.015 - .040] CHAMFER: 1.0 [.040] X 45° MAX SURFACE FINISH: 3.2 μm [125 μin]	PROPRIETARY AND CONFIDENTIAL THE INFORMATION CONTAINED IN THIS DRAWING IS THE SOLE PROPERTY OF AUTOTECH SPORT TUNING CORPORATION. ANY REPRODUCTION IN PART OR AS A WHOLE WITHOUT THE WRITTEN PERMISSION OF AUTOTECH SPORT TUNING CORPORATION IS PROHIBITED.			SCALE: 1:3	SHEET 1 OF 1	

5



4

3

2

1

# DSG AWD VARIANTS

10.309.188WK

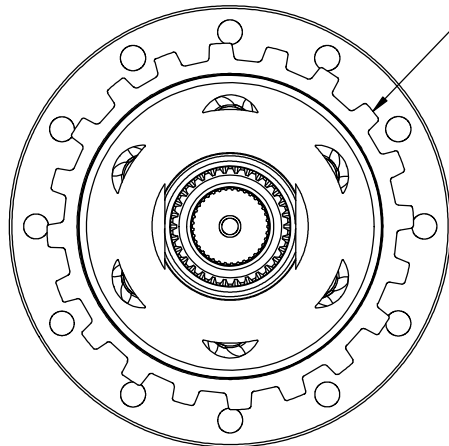
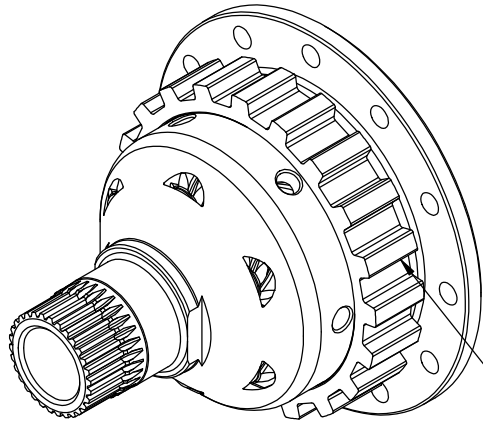

20 TEETH

10.309.188WK

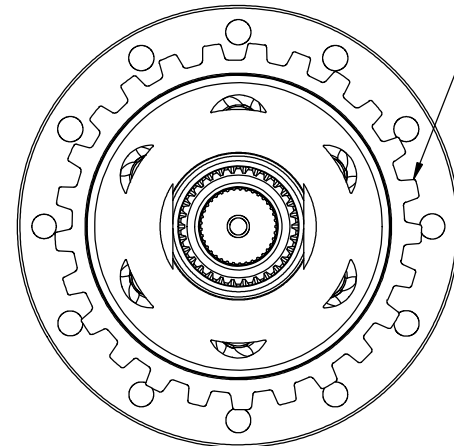
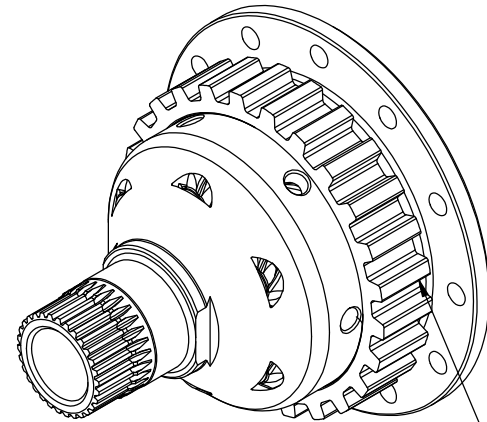

25 TEETH

**DEFAULT TOLERANCES**  
UNLESS OTHERWISE SPECIFIED

X.X ±0.30 [.012]  
X.XX ±0.05 [.002]  
ANGLES ±2°

ALL DIMENSIONS IN:  
MILLIMETERS [INCHES]

**UNDIMENSIONED FEATURES:**  
RADIUS: 0.4 - 1.0 [.015 - .040]  
CHAMFER: 1.0 [.040] X 45° MAX  
SURFACE FINISH: 3.2 µm [125 µin]

A	RELEASED TO PRODUCTION	12/17/12
REV	DESCRIPTION	DATE

**PROPRIETARY AND CONFIDENTIAL**

THE INFORMATION CONTAINED IN THIS DRAWING IS THE SOLE PROPERTY OF AUTOTECH SPORT TUNING CORPORATION. ANY REPRODUCTION IN PART OR AS A WHOLE WITHOUT THE WRITTEN PERMISSION OF AUTOTECH SPORT TUNING CORPORATION IS PROHIBITED.



Autotech Sport  
Tuning Corporation  
29 Journey  
Aliso Viejo, CA  
92656-3333 USA  
+1-949-362-8700

DWG. SIZE	PART NUMBER	REL.
A	248-01R-001	A
DESCRIPTION		
DIFF VARIANTS		
SCALE: 1:3		SHEET 1 OF 1